

Ø0.60吸盘位置

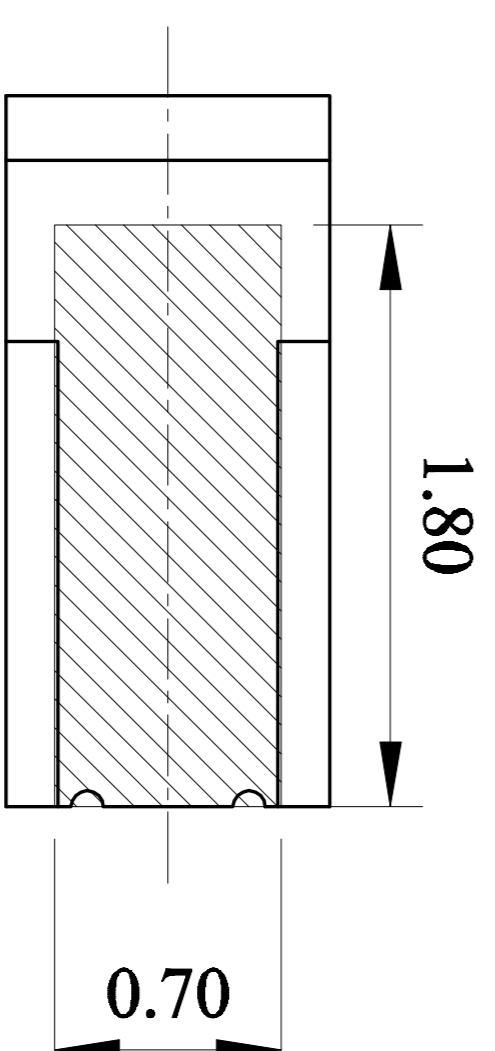

焊盘尺寸

尺寸公差 ±0.05

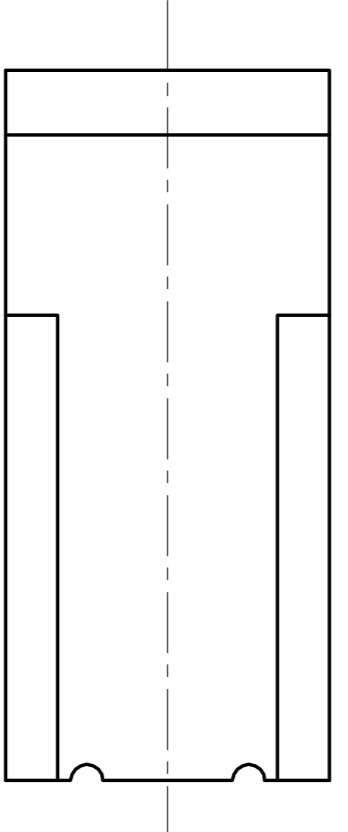
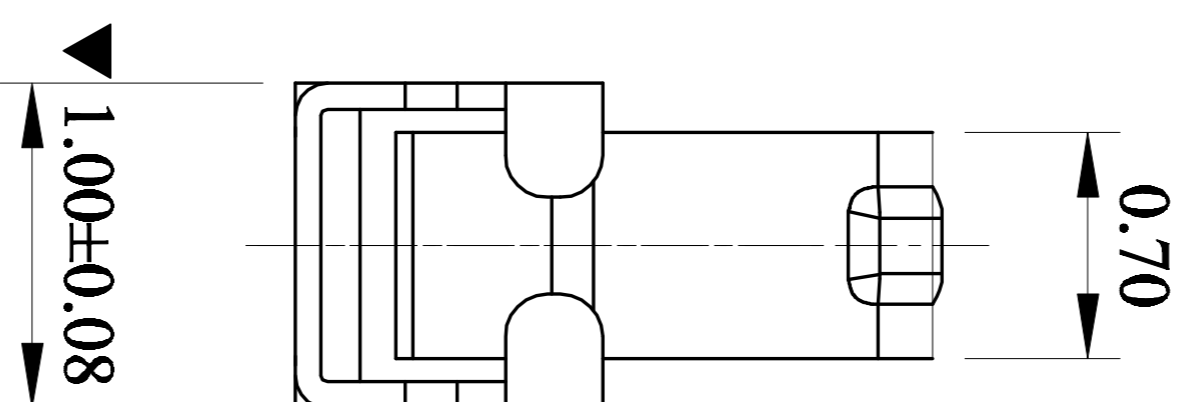
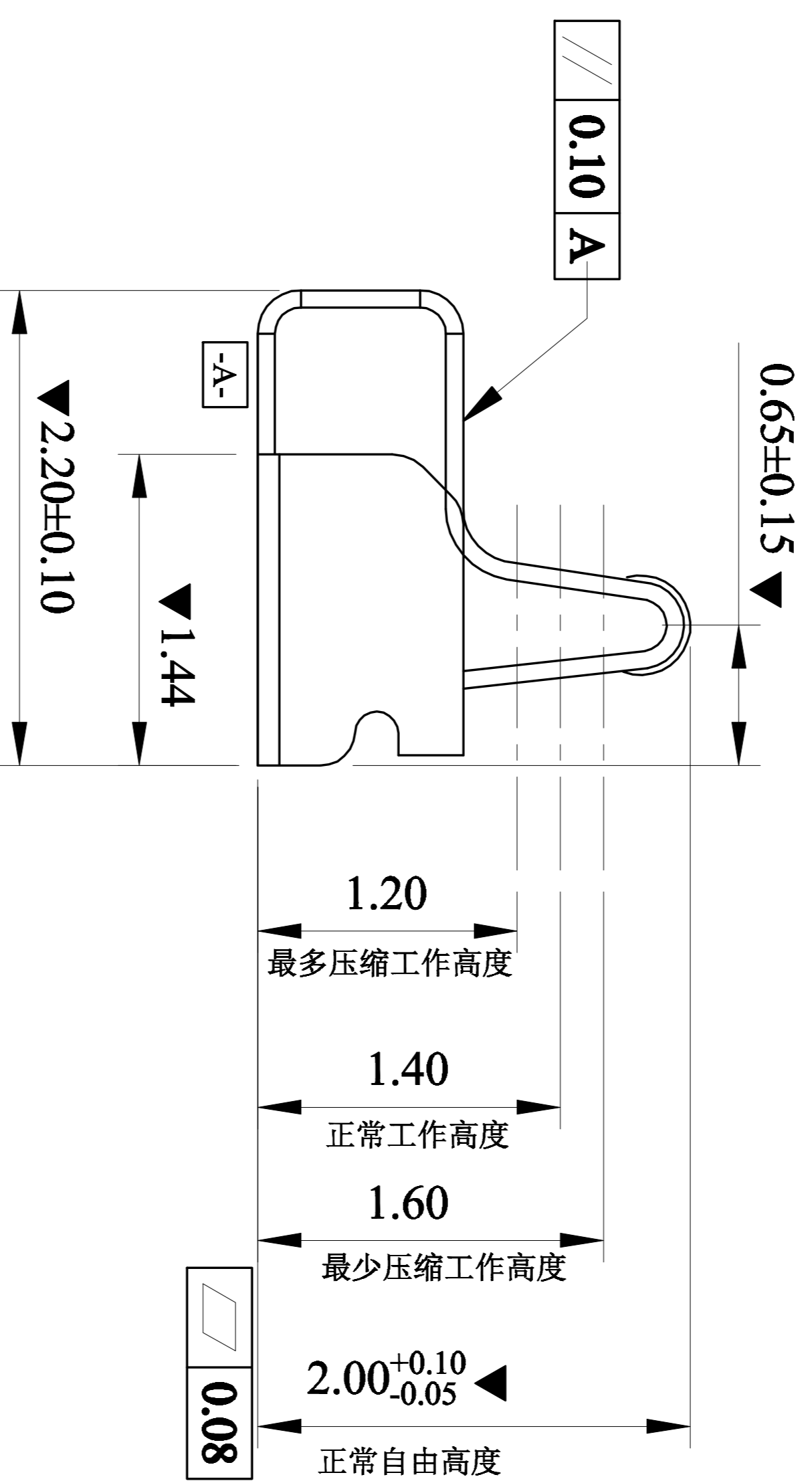
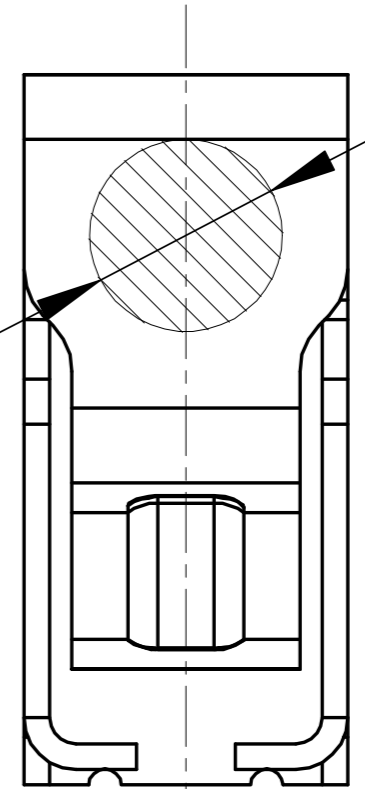
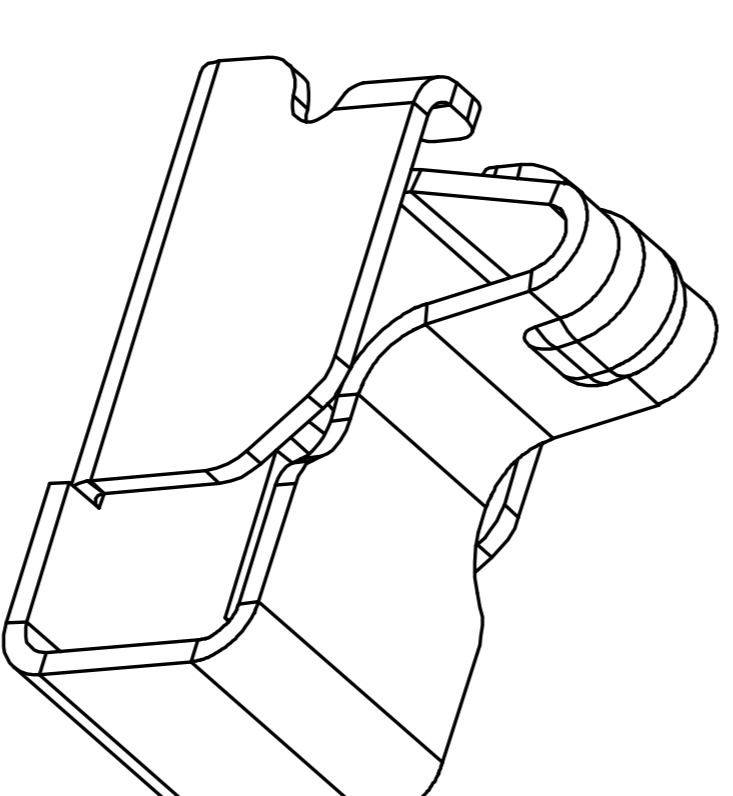

技术要求:

1. 材质: 不锈钢 SUS301, T=0.10±0.005;
2. 端子锡脚焊接面和接触面不可有毛边, 其他部位毛边最大0.03mm;
3. 扭曲: 4.5°/1000mm, 拱形 5mm/1000mm;
4. 标示有“▼”符号的为重点控制和检验尺寸;
5. 未标注之R MAX R0.13;
6. 电镀须满足48小时盐雾测试;
7. 寿命测试>2万次, 产品弹力要求在60gf~80gf之间
8. 镍底50~80u“min, 焊接区域镀金, 接触区域镀金1U“MIN

Rev.	ECN Number	Description	Date	Drawn	Checked	Approved

深圳市金航标电子有限公司		GENERAL TOLERANCE		SCALE: 1:1		DRAWN		DATE		DWG. NO.		TITLE		REV.	
WWW.BDS666.COM		XX. ±0.50		UNIT: mm		CHECK		DATE		681-0096B-1		客户图		A	
型号: KH-221020-TP		X. ±0.35		X.° ±2.0°		APPROVE		DATE		PARTS NO.(INTENDED USE)		RF Antenna Spring, SMT,		SHEET	
0755-83044319		.X ±0.25		.X° ±1.0°				DATE		JXH0096B1		L2.2*W1.0*H2.0mm		1/1	
		.XX ±0.15		.XX° ±0.5°											